

E-Z Worm Composting Bin

Open brush piles and covered compost bins are good for composting outdoor yard waste, but indoor kitchen waste from meal preparation is better composted using a worm bin.



Composting kitchen waste using red worms makes a high quality compost. And, diverting kitchen waste to a worm bin can cut down on garbage disposal use, conserve water and reduce the need for additional fertilizer.

Worm bins can be made from recycled wooden boxes, plastic containers, even small metal garbage cans, but any worm bin must have a tight-fitting lid to keep out pests, and ventilation or drainage holes to provide adequate air circulation and control moisture. You can build your own worm bin using the directions on the back of this page. Cost to build the bin in the above photo depends on current lumber costs.



purchased at various locations in King County. Be sure to use red worms (*Eisenia fetida*) because night crawlers (*Lumbricus terrestris*) or regular earth worms don't eat organic waste. Bury kitchen fruit and vegetable wastes, moldy bread, grains and cereals, coffee grounds (with filters) and tea bags. Don't put in dairy products, meats, fats or oils. Limit the amount of citrus.

After a few months, move the partially finished compost to one side of the bin and add new bedding to the other side. Bury food wastes in the new bedding; the worms will migrate over within a few months. Finished compost can then be harvested, the newly emptied half of the bin can be re-bedded and the process repeated. Worm bins don't produce large amounts of compost, but it is very

Materials required:

- One 4' x 8' sheet of 1/2" exterior plywood
- One 14' utility 2x4 and one 16' utility 2x4
- 3/4 pound 6d galvanized nails or 1 1/4" drywall screws
- Twelve 16d galvanized nails or 4" drywall screws
- Two 3" galvanized door hinges with screws

Tools required:

- Tape measure
- Skill saw and or rip hand saw
- Hammer
- Long straight edge or chalk snap line
- Screw driver
- Drill with 3/8" bit.
- Saw horses

How to compost with worms:

Select a bin location in the shade. Fill to the top with shredded newspaper, cardboard, paper egg cartons, wood shavings or brown leaves. Add water until all the bedding is thoroughly moistened (like a wrung out sponge). Cardboard or a couple sections of newspaper, peat moss or coconut coir on the bottom will absorb extra moisture. Add red worms to the mix. A starter batch of worms can be dug out of a friend's worm bin or

nutritious. Sprinkle a handful in a hole when transplanting seedlings, a half inch as a top dressing in your garden or one quarter inch on the surface of potted plants.

DIRECTIONS TO BUILD WORM BIN ON BACK



King County

Department of
Natural Resources and Parks
Solid Waste Division

Five Steps to:
**Natural
Yard Care**





E-Z Worm Composting Bin

How to build

Construct the base:

1. Measure and cut plywood as indicated in **figure A**. To make the base, cut the 14-foot 2x4 into two 48-inch and three 20-inch sections. (The remaining 12-inch piece will be used to make the sides.)
2. Nail or screw the 2x4s together on edge with two 16d nails or 4-inch drywall screws at each joint, as illustrated in **figure B**. Nail or screw the plywood base onto the 2x4 frame.

Construct the box:

1. Cut three 12-inch pieces from the 16-foot 2x4.
2. With the 12-inch piece remaining from the base 2x4, nail or screw the 12-inch 2x4s under the end of each side panel

so that the 2x4s are flush with the top and side edges of the plywood.

3. Nail or screw the side panels onto the base frame. Then nail or screw the ends onto the base and sides. To reinforce the box, place a nail or screw staggered every three to five inches wherever plywood and 2x4 meet.
4. Drill twelve 3/8" drainage holes in the bottom of the box.

Construct the lid

1. Cut the remaining 16-foot 2x4 into two 51-inch pieces and two 20-inch pieces.
2. Place these pieces flat in a rectangle with the shorter pieces on the inside, as shown in **figure C**.
3. Center the lid on the plywood frame

and attach with nails or screws.

4. Hinge the lid to the base at both ends of the backside of the bin. Each hinge should be screwed to the 2x4 framing of the lid and the 2x4 framing of the box so that the lid will stand upright when opened (**figure D**).

To attach the lid to the rest of the worm bin, center the lid on top of the constructed box. (The lid will overhang the box.)

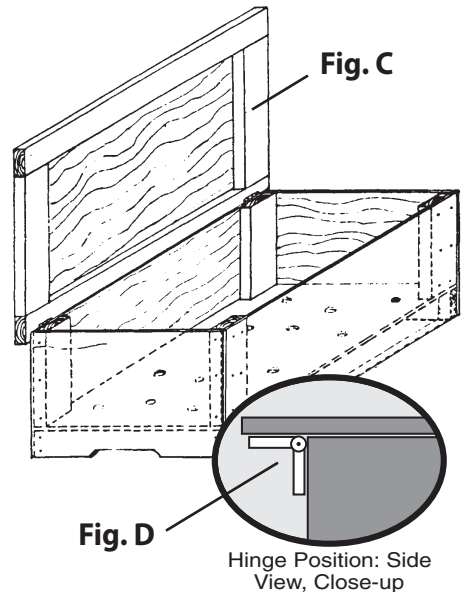
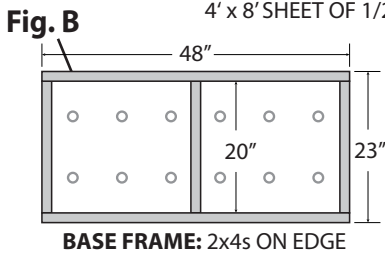
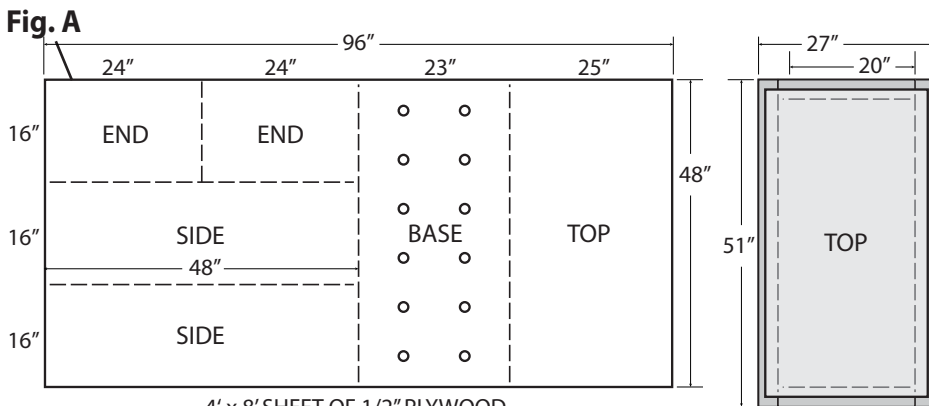

Building tips:

1. Use drywall screws and a drill with a screw bit to speed construction and strengthen bin.
2. Avoid treated wood as the chemical treatment may harm worms and contaminate compost.

Remember to use eye and ear protection.



Bin measures approximately 51" in length, 27" in width, and 17" in height.

For more information and for current sources of worms: Call the Garden Hotline at **206-633-0224** or email help@gardenhotline.org

Additional Resources:

- Soil and composting and natural yard care: www.kingcounty.gov/soils
- Yard and garden topics: www.kingcounty.gov/natural-yard
- Kitchen waste composting with worms: www.kingcounty.gov/soils
Click on *Documents*.

Alternative Formats On Request
206-296-4466 • TTY Relay: 711
1-800-325-6165 ext. 6-4466